

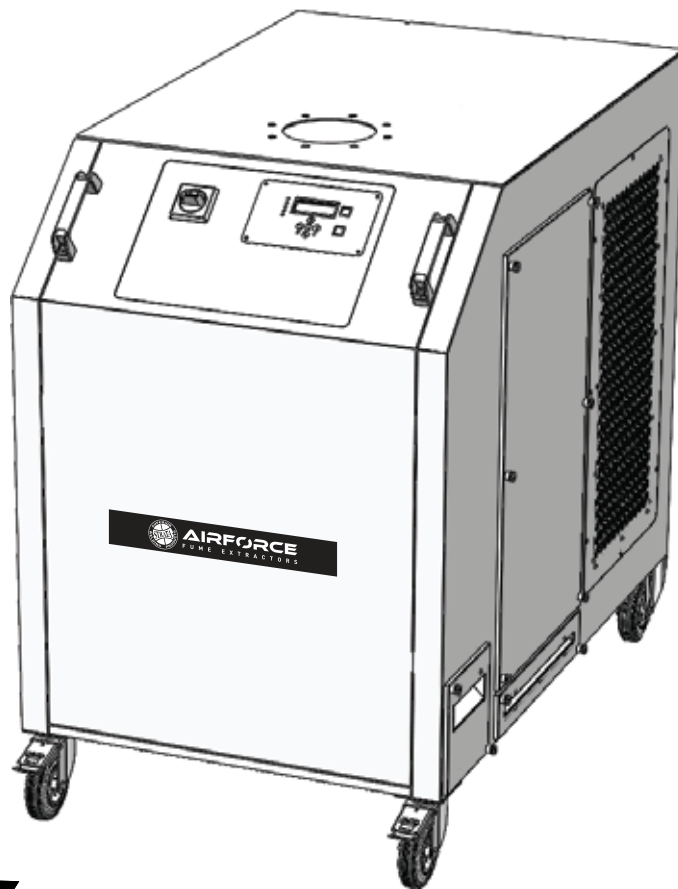

AIRFORCE FE320 HD

HEAVY DUTY WELDING FUME EXTRACTOR

OPERATING INSTRUCTIONS



👉 IMPORTANT!

Read these Operating Instructions Completely before attempting to use this machine. Save this manual and keep it handy for quick reference. Pay particular attention to the safety instructions we have provided for your protection. Contact your distributor if you do not fully understand anything in this manual.





CONTENTS

1. GENERAL INFORMATION	4
1.1. Introduction.....	4
1.2. Information on copyright and related rights.....	4
1.3. Instructions for the user	4
2. SAFETY	5
2.1. General information	5
2.2. Warnings and symbols in the user manual	5
2.3. Signs applied by the user.....	5
2.4. Safety warnings for the operator	6
2.5. Safety warnings for maintenance and troubleshooting.....	6
2.6. Warning about specific dangers	7
3. UNIT DESCRIPTION	8
3.1. Purpose.....	8
3.2. Features and versions.....	9
3.3. Proper use	9
3.4. Improper use of the unit	10
3.5. Marks and labels on the unit.....	11
3.6. Residual risk.....	12
4. TRANSPORT AND STORAGE	12
4.1. Transport	12
4.2. Storage.....	12
5. ASSEMBLY.....	13
5.1. Unpacking and castors assembling.....	13
5.2. Assembling the extraction arm	14
5.3. Electric and pneumatic connection	14
5.4. Active carbons filter (optional).....	15
6. USE.....	15
6.1. User qualification.....	15
6.2. Control panel	16
6.3. Correct positioning of the capture hood	17
6.4. Start of the unit	18
6.5. Start of the unit with automatic START-STOP device.....	18
6.6. Automatic filter cleaning by compressed air.....	20
7. REGULAR MAINTENANCE	21
7.1. CARE.....	22
7.2. Ordinary maintenance.....	22



FE320 HD

7.3.	Dust collector drawers.....	22
7.4.	Safety filter and active carbons filter	23
7.5.	Replacement of filters	24
7.6.	Digital control panel: alarms and alarm reset	27
7.7.	Troubleshooting	29
7.8.	Emergency measures.....	30
8.	DISPOSAL	30
8.1.	Plastics	30
8.2.	Metals.....	30
8.3.	Filter media.....	30
9.	ATTACHMENTS	31
9.1.	Technical data Airforce FE320 HD / 1-2 arms / 2 cartridges	31
9.2.	Spare parts and accessories	32
9.3.	Dimensional drawing.....	33
9.4.	Wiring diagram Airforce FE320 HD 230V.....	34
9.5.	Wiring diagram Airforce FE320 HD 400V.....	34
9.6.	Pneumatic diagram FE320HD	35
10.	WARRANTY.....	36



1. GENERAL INFORMATION

1.1. Introduction

This user manual provides important information for the correct and safe operation of the mobile filter unit Airforce FE320 HD suitable for extraction of welding fumes.

The instructions contained in this manual help to avoid dangers, to reduce repair costs and machine downtime and to increase the reliability and lifetime of the unit.

The user manual shall always be at hand; all information and warnings contained therein shall be read, observed and followed by all people who work by the unit and are involved in tasks, such as:

- transport and assembly;
- normal use of the unit during work;
- maintenance (replacement of filters, troubleshooting);
- disposal of the unit and its components.

1.2. Information on copyright and related rights

All information included in this instruction manual must be treated confidentially and may be made available and accessible only to authorized people.

It may be disclosed to third parties only with the prior written consent of the Manufacturer.

All documentation is protected under the copyright law.

Any reproduction, total or partial, of this document, as well as its use or transmission without prior and explicit authorization by the Manufacturer, is prohibited.

Any violation of this prohibition is punishable by law and involves penalties.

All rights relating to industrial property rights are reserved to the Manufacturer.

1.3. Instructions for the user

These Instructions are an integral part of the unit Airforce FE320 HD.

The user must ensure that all personnel in charge of the unit have adequate knowledge of these Instructions.

The user is required to complete the Manual with instructions based on national regulations for injury prevention and environmental protection, including information on surveillance and notification obligations, in order to consider specific requirements, such as organization of work, working methods and personnel involved.

In addition to the instructions and regulations for the prevention of accidents, in force in the country and in the place where the unit is used, it is necessary to comply with the common technical principles for a safe and correct use of the unit.

The user shall not make any modifications to the unit, nor add parts or adjust it without permission by the Manufacturer because this could jeopardize its safety!

The spare parts used shall correspond to the technical specs established by the Manufacturer.

Always use original spare parts to ensure correspondence of the unit to the technical specifications.

Allow only trained and expert personnel for the operation, maintenance, repair and transport of the unit.

Establish individual responsibilities for operation, configuration, maintenance and repair.



2. SAFETY

2.1. General information

The unit was developed and manufactured using the latest technology and in accordance with the general workplace safety guidelines.

However, the use of the unit could present risks for the operator or risks of damage to the unit and other objects:

- If the personnel in charge has not received instructions or training;
- In case of use that is not in accordance with the intended purpose;
- In case of maintenance that is not carried out as indicated in this manual.

2.2. Warnings and symbols in the user manual



DANGER

This warning indicates an imminent dangerous situation.
Not respecting it can result in death or serious injury.



WARNING

This warning indicates a possible dangerous situation.
Not respecting it can result in death or serious injury.



WARNING

This warning indicates a possible dangerous situation.
Not respecting it can result in minor injury or material damage.



INFO

This warning provides useful information for safe and proper use.

- The point in bold marks the work and / or operating procedure.
The procedures need be performed in sequence.
- Any list is marked with a horizontal dash.

2.3. Signs applied by the user

The user is responsible for the application of signs on the unit or in the near area.

Such signs may concern, for example, the obligation to wear personal protective equipment (PPE).
Refer to the local regulations for advice.



FE320 HD

2.4. Safety warnings for the operator

Before using the unit, the operator in charge must be suitably informed and trained for the use of the unit and the relevant materials and means.

The unit must only be used in perfect technical condition and in compliance with the intended purposes, the safety standards and the warnings relating to dangers as reported in this Manual.

All failures, especially those that can jeopardize safety, shall be removed immediately!

Each person responsible for commissioning, use or maintenance of the unit must be familiar with these instructions and must have understood their content, especially paragraph 2 Safety.

It is not enough to read the manual for the first time when you are already working.

This is especially true for people who work on the unit only occasionally.

The manual shall always be available near the unit.

No liability is accepted for damage or injury due to failure to comply with these instructions.

Observe the current workplace precaution rules, as well as other general and standard technical safety and hygiene tips.

Individual responsibilities for the various maintenance and repair operations must be clearly established and respected. Only in this way malfunctions can be avoided - especially in dangerous situations.

The user shall ensure that the personnel responsible for use and maintenance of the unit shall wear personal protective equipment (PPE). These are mainly safety shoes, goggles and protective gloves.

Operators must not wear long loose hair, baggy clothing or jewelry! There is a risk of being trapped or drawn in by the moving parts of the unit!

In case of any changes on the unit, that may affect safety, switch off the equipment immediately, secure it and report the incident to the department / person in charge!

Interventions on the unit can only be carried out by competent, reliable and trained personnel.

Personnel undergoing training or in a training program may only be permitted to work on the unit under the constant supervision of a trained person.

2.5. Safety warnings for maintenance and troubleshooting

For all maintenance and troubleshooting, ensure to use suitable personal protective equipment.

Before proceeding with any maintenance work, clean the unit.

An industrial vacuum cleaner with H efficiency class for dust can be helpful.

The preparation, maintenance and repair operations, as well as the detection of faults can only be carried out if the unit is without power supply:

- Remove the plug from the mains supply.
- Disconnect the compressed air supply.

All screws that were loosened during maintenance and repair work need always be fastened again!

If so foreseen, the screws must be tightened with a torque wrench.

Before proceeding with maintenance and repairs it is necessary to remove all impurities, especially on the parts fastened with screws.



FE320 HD

2.6. Warning about specific dangers



DANGER

All work on the electrical device of the unit shall be carried out exclusively by a qualified electrician or by personnel with the necessary training, under the direction and supervision of a qualified electrician and in accordance with the relevant safety standards.

Before any activity on the unit, it is necessary to disconnect the electric plug from the mains supply, to prevent accidental restarting.

Use only original fuses with the prescribed current limit.

All electrical components to be inspected, maintained and repaired must be disconnected. Block the devices used to disconnect the voltage, in order to avoid accidental or automatic restart.

First check the absence of voltage on the electric components, then isolate the adjacent components. During repairs, be careful not to modify the factory parameters so as not to jeopardize safety.

Check the cables regularly and replace in case of damage.



WARNING

Skin contact with welding powders etc. can cause irritation to sensitive people.

Repair and maintenance of the unit must only be carried out by qualified and authorized personnel, in compliance with safety requirements and accident prevention regulations in force.

Danger of serious damages to respiratory system.

To prevent contact with dust and inhalation, use protective clothing and gloves and an assisted ventilation device to protect the respiratory tissue.

During repairs and maintenance interventions, avoid diffusion of dangerous dust, in order to prevent health damage even of people not directly affected.



WARNING

The unit can produce noise emissions, specified in detail in the technical data.

If used with other machinery or due to the characteristics of the place of use, the unit may generate a higher sound level.

In this case, the person in charge is required to provide the operators with adequate protective equipment.



FE320 HD

3. UNIT DESCRIPTION

3.1.Purpose

The unit is a heavy duty mobile device suitable for filtration of fumes and dust from welding processes; these can be extracted directly at source, with a high separation rate in compliance with international standards.

The unit can be equipped with one or two articulated arms with capture hood, or with an adapter and a flexible hose.

The fumes (rich in polluting particulate) are purified through a multi-stage filtration process, before being released back in the workplace.

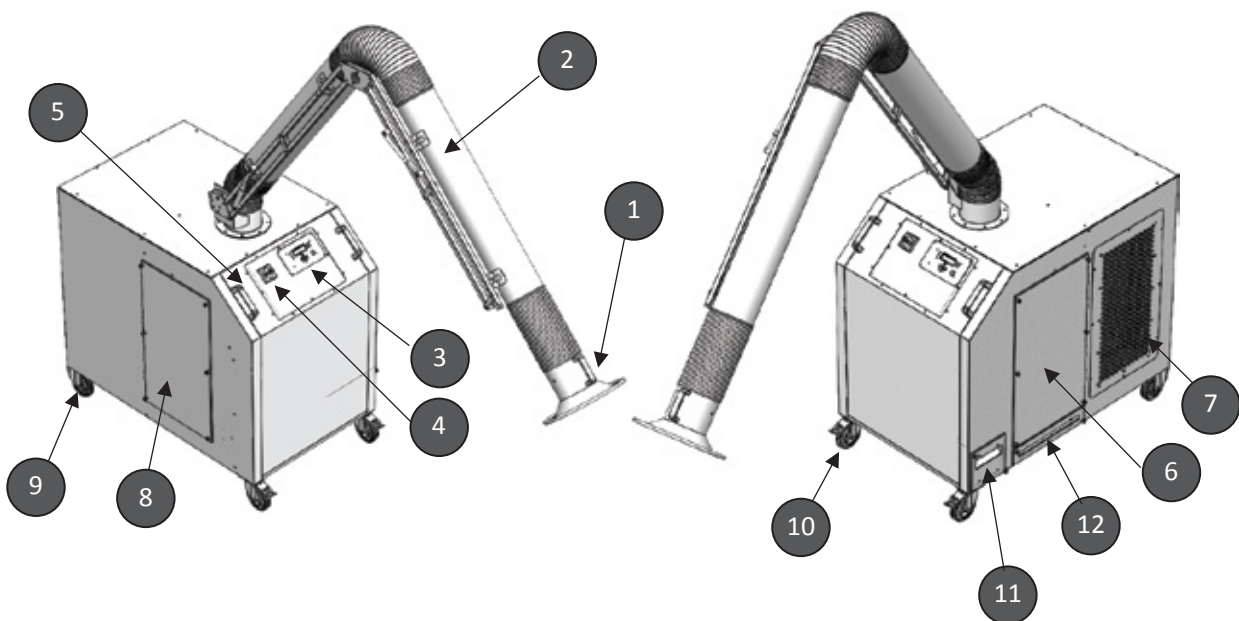

Pos.	Description
1	Capture hood
2	Articulated arm
3	Control panel
4	ON-OFF switch
5	Handles
6	Filter inspection door

Pos.	Description
7	Clean air discharge grid
8	Cleaning device - inspection door
9	Fix wheels
10	Swivel wheels with brake
11	Collector drawer – heavy dust
12	Collector drawer – fine dust



FE320 HD

3.2. Features and versions

The mobile air cleaner is available in two versions, with one or two extraction arms.

- **Airforce FE320 HD**
with 2 cartridge filters - mechanical filtration
filter efficiency: $\geq 99\%$ | M (sec. DIN 660335-2-69)

Optional Accessory Items



ARMOLIGHT16030

Lighting kit for round capture hood on arm.



ARMOSPARK0160

Spark arrestor filter to fit in the round hood (for heavy grinding and protects/prolongs main filter life)

3.3. Proper use

The unit has been conceived to extract and filter the welding fumes generated by industrial welding processes, directly at source. In principle, the unit can be used in all work processes with emission of welding fumes. It is also suitable to extract dust from grinding and manual plasma cutting processes. However, it is necessary to prevent the unit from sucking in many white-hot particles, by applying particular devices on the capture hood.

Pay attention to the dimensions and further data that are mentioned in the technical data sheet.

For the extraction of welding fumes containing carcinogenic substances, produced by the welding processes of alloy steels (such as stainless steel etc.), only those devices may be used according to current regulations that have been tested and approved for air recirculation.



FE320 HD



INFO

The model FE320 HD has been approved for extraction of fumes from welding processes with alloy steels and complies with W3 efficiency class requisites, according to international norms UNI EN ISO 21904-1:2020 and UNI EN ISO 21904-2:2020.



INFO

Carefully read and comply with the instructions in chapter "9.1 Technical data of the unit". The use in accordance with the instructions of this manual also means following the specific instructions:

- for safety;
- for use and setting;
- for maintenance and repair,

mentioned in this user manual.

Any further or different use is to be considered as non-compliant.

The user of the unit is the sole responsible for any damage resulting from such non-compliant use.

This also applies to arbitrary interventions and unauthorized modifications on the unit.

3.4. Improper use of the unit

The unit is not suitable for use in hazardous areas falling under ATEX regulation.

Furthermore, the equipment should not be used in the following cases:

- Applications not corresponding to the intended purpose or not indicated for proper use of the unit and in which the air to be extracted:
 - contains liquids that may contaminate the air flow with vapors, aerosols and oils;
 - contains easily flammable dusts and / or substances that may cause explosive mixtures or atmospheres;
 - contains other aggressive or abrasive powders that may damage the unit and its filters;
 - contains organic and toxic substances / components (VOCs) which are released during the separation process. Only by inserting the active carbons filter (optional) the unit becomes suitable for filtration of these substances.
- The unit is not suited for installation in an outdoor area, where it may be exposed to atmospheric agents: the unit must be installed exclusively in closed and / or repaired buildings. Only a special version of the unit (with specific indications for outdoors) can be installed outside.

Any waste, such as for example collected particles, may contain harmful substances, therefore they must not be delivered to landfills for municipal waste. It is necessary to provide for an ecological disposal according to local regulations.

If the unit is used in accordance with its intended purpose, there is no reasonably foreseeable risk of improper use that might endanger health and safety of personnel.





FE320 HD

3.5. Marks and labels on the unit

The unit has marks and labels which, if damaged or removed, need be immediately replaced with new ones in the same position.

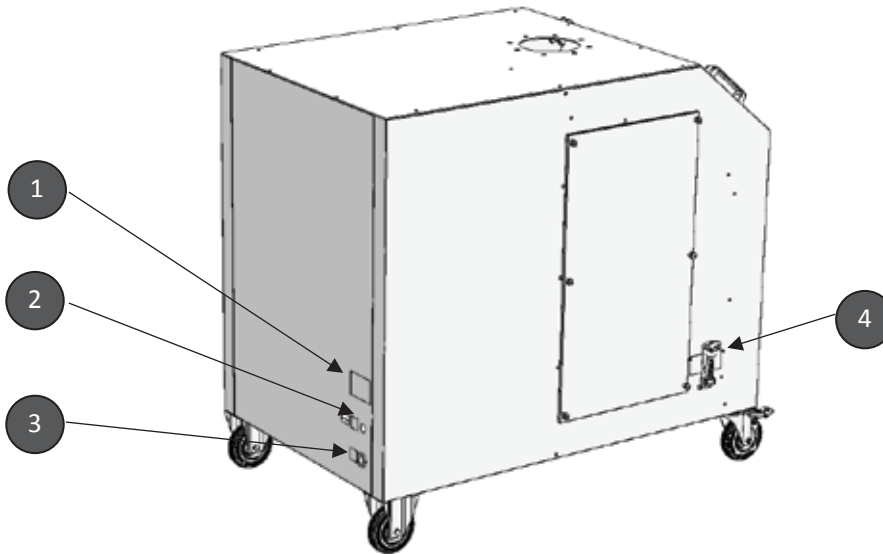
The user may have the obligation to place other marks and labels on the unit and in the surrounding area, e.g. referring to the local regulations for the use of personal protective equipment (PPE).



Marks	Description	Position	Note
Label [1]	Rating plate and CE mark	1	
Label [2]	Mains supply	2	
Label [3]	Compressed air supply	3	
Label [4]	Instructions for the earth cable of the welding unit	4	
Label [5]	ECM ENTE CERTIFICAZIONE MACCHINE test mark	2	
Label [6]	W3 efficiency class for welding fumes according ISO 21904	3	



FE320 HD

3.6. Residual risk

The use of the unit involves a residual risk as illustrated below, in spite of all safety measures.

All users of the unit must be aware of the residual risk and follow the instructions to avoid any injury or damage.



WARNING

Risk of serious damage to the respiratory system - wear a protective device in class FFP2 or higher.

Skin contact with cutting fumes etc. can cause skin irritation in sensitive individuals. Wear protective clothing.

Before carrying out any welding job, make sure that the unit is positioned / installed correctly, that the filters are complete and intact and that the unit is active!

The unit can perform all its functions only when it has been switched on.

By replacing the various filters that make up the filtering section, the skin can come into contact with the separated powder and the processes carried out can volatilize this powder. It is necessary and mandatory to wear a mask and a protective suit.

Burning material sucked in and trapped in one of the filters, can cause smoldering. Switch off the unit, close the manual damper in the capture hood, and allow the unit to cool down in a controlled manner.

4. TRANSPORT AND STORAGE

4.1. Transport



DANGER

Danger of death from crushing during unloading and transport.

Improper maneuvers during lifting and transport can cause the pallet with the unit to overturn and fall.

- Never stand under suspended loads.

A transpallet or forklift truck are suitable for transporting any pallet with the unit.

The weight of the unit is indicated on the rating plate.

4.2. Storage

The unit shall be stored in its original packaging at an ambient temperature between -20° C and +50° C in a dry and clean place.

The packaging must not be damaged by other objects.

For all units, the duration of storage is irrelevant.



5. ASSEMBLY



WARNING

Risk of serious injury when assembling the suction arm due to gas spring preload. A safety lock is provided on the metal articulating arm assembly. Improper handling can lead to risk of abrupt displacement of the metal articulating arm assembly, resulting in severe injuries in the face or crushing of the fingers!



INFO

The user is required to appoint a specially trained technician to install the unit. The assembling operations require the intervention of two persons.

5.1. Unpacking and castors assembling

The unit is delivered on a wooden pallet and protected by a cardboard box.

Pallet and box are held together by two straps.

A copy of the rating plate of the unit is applied also outside the box.

Prepare unpackaging as follows:

- Cut the straps with scissors or cutter;
- Lift up the cardboard box;
- Remove any additional packages contained inside and place them on the ground in a stable manner;
- Using scissors or cutter, cut the strap blocking the unit on the pallet;
- Remove any packaging materials such as bubble nylon;
- Shift the unit about 30 cm off the pallet, from the front side;
- Place the castors with brakes under the unit;
- Fix them in the unit using the screws that are provided in the package;
- Shift the unit about 30 cm off the pallet, from one side;
- Position and fit one rear castor;
- Extract the pallet from beneath the unit and fit the second rear castor.

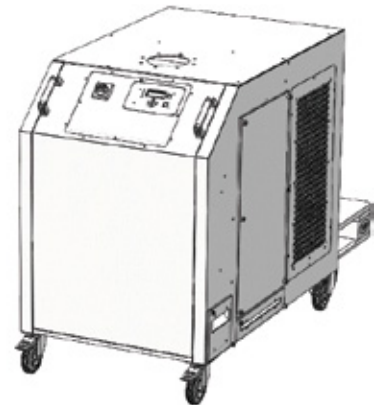
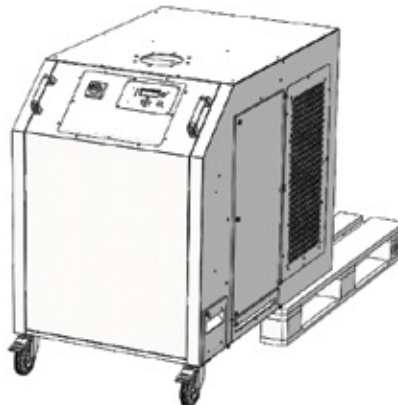
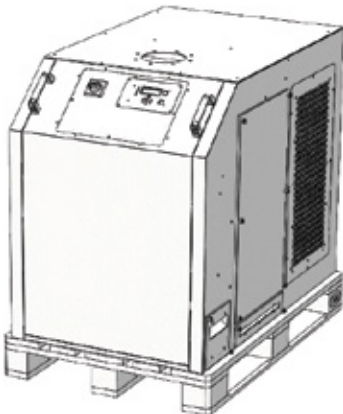



FE320 HD

5.2. Assembling the extraction arm

The extraction arm is made up of three main components – rotating part, metal pantograph and capture hood.

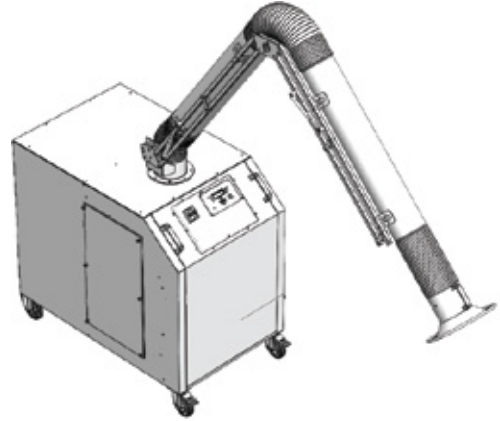

5.3. Electric and pneumatic connection

Airforce FE320 HD is a plug and play unit and all connections are already provided.

It is only necessary to connect the unit to the mains supply by the cable included in the unit (1) and then connect the compressed air on the specific connector (2) (1/2" female threaded connector).



INFO

Use dry compressed air in purity class 2_(dust):4_(water):2_(oil) according ISO 8573-1

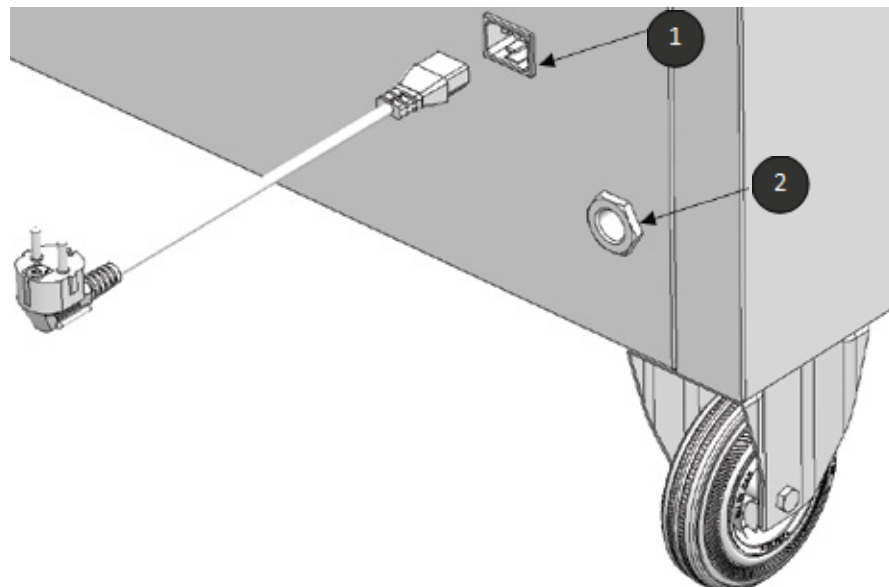



FE320 HD

5.4. Active carbons filter (optional)

Whenever required a further filtration stage can be added on the unit Airforce FE320 HD. This is the active carbons filter (used to capture VOC Volatile Organic Compounds). To insert these filters the air grids need be removed: behind the grid there is a specific slot for the 5kg active carbons filters.



INFO

It is necessary to use protective gloves to avoid possible cuts on hands.
Active carbon is non-toxic and has no effect in case of skin contact.

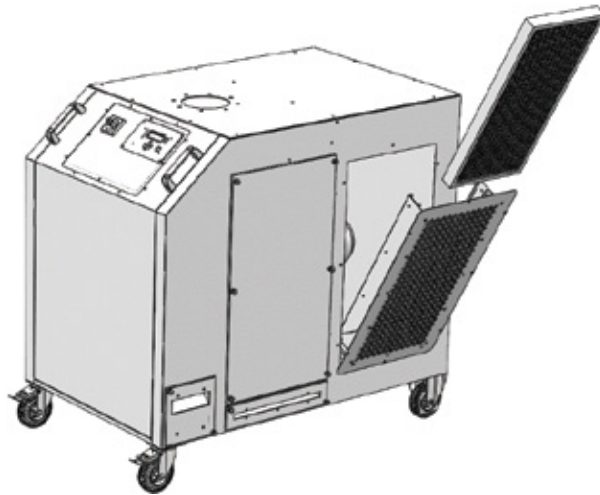

6. USE

Anyone involved in the use, maintenance and repair of the unit must have read and understood this user manual as well as the instructions for accessories and related devices.

6.1. User qualification

The user of the unit can only authorize the use of the unit by personnel with a good knowledge of these operations.

Knowing the unit means that the operators have been trained on the functions, and know the user manual and operating instructions.

The unit shall only be used by qualified or duly trained personnel. Only in this way is it possible to ensure working in a safe manner and in awareness of dangers.

6.2. Control panel

On the front of the unit there is the control panel which is made up of electronic and electromechanical devices.

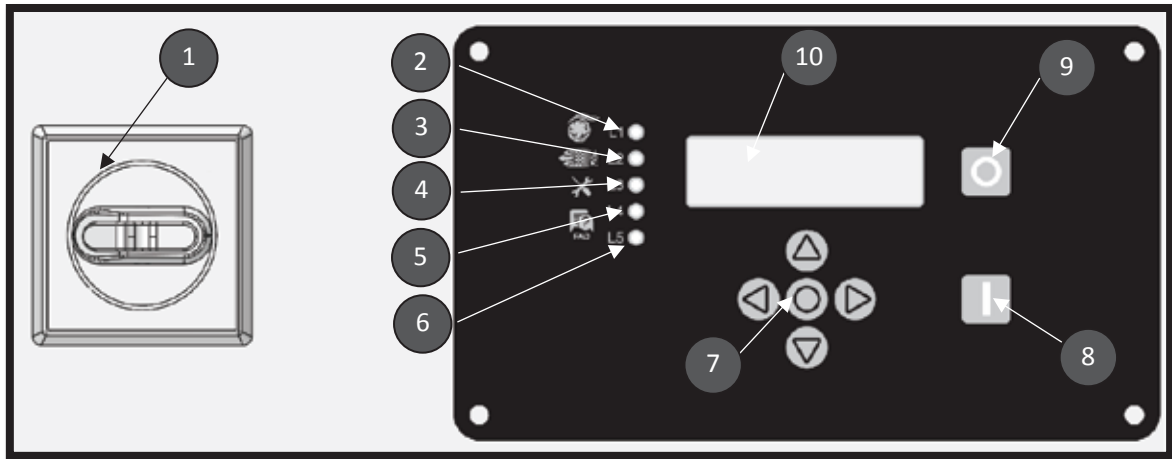

Pos.	Description	Notes
1	ON-OFF switch	
2	LED Electric fan is running	
3	LED Replace filter	
4	LED Maintenance	
5	LED Generic alarm	
6	LED Generic alarm	
7	Control panel keys	
8	ON button to turn on the extraction	
9	OFF button to turn off the extraction	
10	Pcb data reading display	

Below the detailed description:

- *[Position 1.]*
By turning the switch clockwise, the unit is turned on.
- *[Position 2.]*
After pressing the button ON (pos.7) the signaling LED lights up with a steady green light and indicates that the electric motor has been powered and is running.
- *[Position 3.]*
LED indicator with steady red light, is triggered by the filter pressure differential gauge.
- *[Position 4.]*
LED indicator with steady red light, turns on after 600 hours of operation.
- *[Position 5. – 6.]*
LED for generic alarms.
- *[Position 7.]*
Specific buttons on the control panel to move through the menus and / or modify the parameters.
- *[Position 8. – 9.]*
ON key to start extraction - hold for 3s.
OFF key to switch off extraction - hold for 3s.
- *[Position 10.]*
Display showing all information about the pcb.



INFO



A safe and effective capture of the welding fumes is only possible if there is enough extraction capacity.

The more clogged the filters the narrower the air flow, with a reduction of the extraction capacity!

The acoustic alarm beeps as soon as the extraction capacity falls down below the minimum value.

At that point, the filter needs replacing!

The same happens even if the manual damper in the extraction hood is too closed, significantly reducing the extraction capacity. In this case, open the manual damper.

6.3. Correct positioning of the capture hood

The articulated arm with its capture hood (provided with the unit) has been conceived to make positioning and approaching the source of fumes very easy and dynamic. The capture hood remains in the required position thanks to a multidirectional joint.

In addition, both the hood and the arm can rotate 360°, allowing the suction of fumes in almost any position.

Correct positioning of the capture hood is an essential prerequisite in order to guarantee efficient extraction of welding fumes.

The following figure shows the correct positioning.

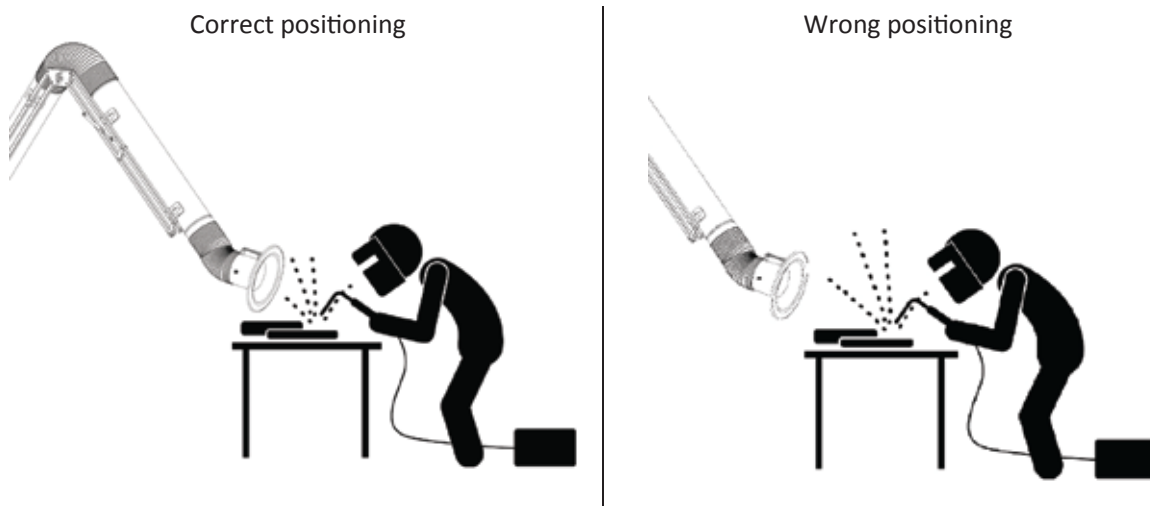

- Position the articulated arm so that the capture hood is positioned transversely to the welding point, at a distance of approximately 25 cm.
- The capture hood must be positioned in such a way as to allow efficient extraction of welding fumes, according to their direction as the temperature and the suction radius vary.
- Always position the capture hood near the relevant welding point.



FE320 HD



WARNING

In case of incorrect positioning of the capture hood and poor extraction capacity, an efficient extraction of the air containing dangerous substances cannot be guaranteed. In this case, the hazardous substances could penetrate the user's respiratory system, causing damage to health!

6.4. Start of the unit

- Connect the unit to the mains supply and to the compressed air circuit; notice the data indicated on the rating plate.
- Switch ON the unit using the yellow-red main switch.
- The control panel is now active, press the ON key on the panel for 3s.
- The fan starts running and the green light indicates that the unit is functioning correctly.
- Finally, always adjust the capture hood in position according to the work process.
- Before turning off the unit by the yellow-red main switch, wait until the automatic self-cleaning unit (10 minutes) has come to its end.

6.5. Start of the unit with automatic START-STOP device

The unit is equipped with an automatic START-STOP electronic device which automatically starts and stops the extraction according to the actual operation of the welding unit.

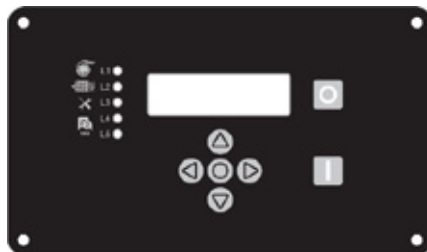

[picture 1: layout of the control panel]

The unit with automatic start and stop function has a special clamp on the side panel and also specific indications in the display.

After having turned on the main switch of the unit, the pcb will turn on giving the following information:

- Software version installed
- Name and p/n of the unit
- Then the following information will be shown in the display: START-STOP ACTIVATED.
- The extraction LED  will be flashing.

In this mode the unit is ready to work and it is sufficient to start welding to activate the fume extraction. The unit is already set to stop extracting after 1 minute from the last welding cycle.



FE320 HD

MANUAL OPERATION

It is possible to start the unit manually by pressing the ON button for a few seconds.

The message: MANUAL START ACTIVE will appear.

The operation of the filter unit will be active until the OFF button is pressed.

After turning off the extraction, the unit will automatically return to the automatic Start / Stop mode.

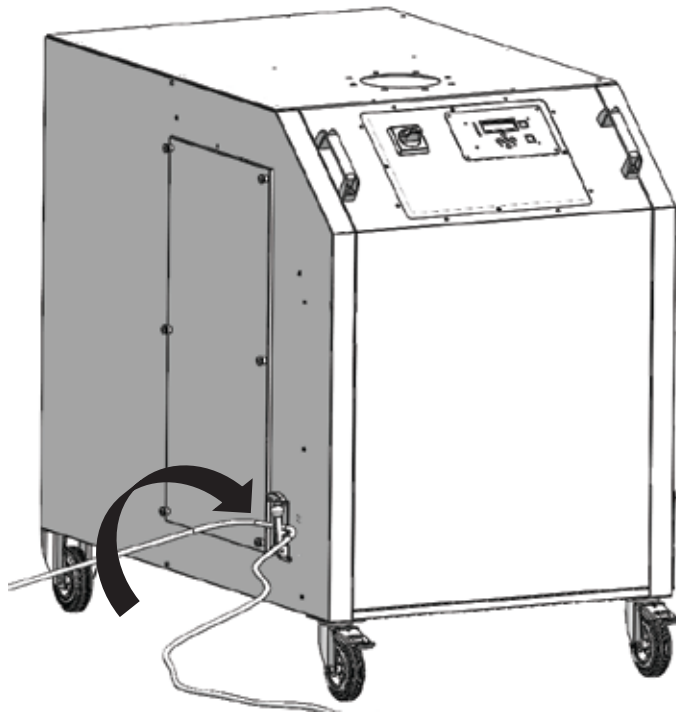

To ensure proper operation of the automatic Start / Stop device, it is essential that the ground cable of the welding unit is placed on the metal cabinet of the filter unit and locked in position by the special clamp. Check that the ground cable is well in contact with the metal cabinet of the unit, as shown in the figure.





FE320 HD

6.6. Automatic filter cleaning by compressed air

The unit is provided with an automatic cleaning system by a compressed air jet.

The cleaning cycle starts when the front panel turns to OFF (extraction is off, the yellow-red main switch is ON) and keeps going for 10 min.

Thanks to the automatic Start/Stop function the extraction and the cleaning cycle are calibrated automatically as shown in the following diagram:

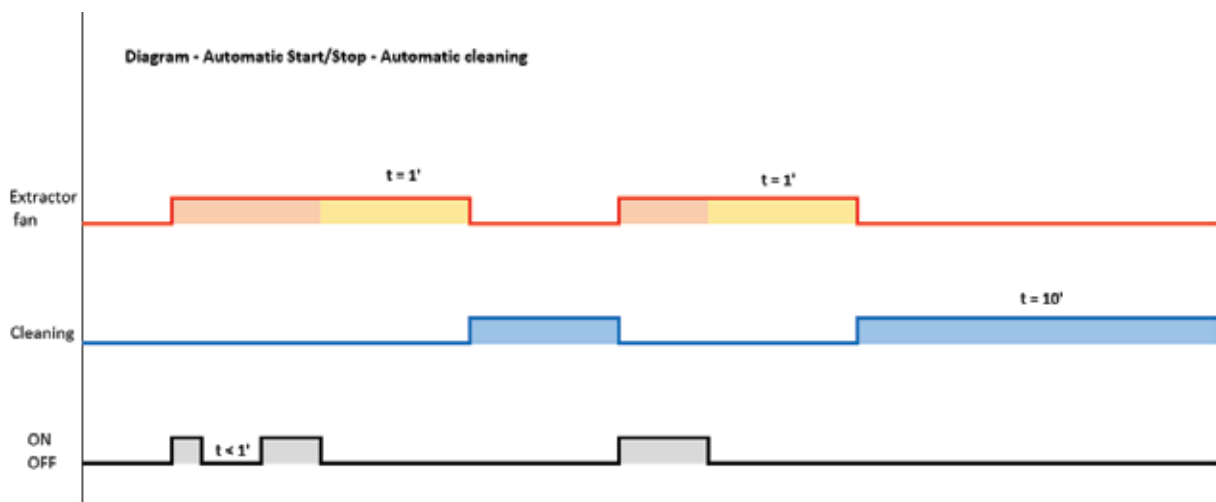

INFO

Turn off the unit by the key OFF or O on the front panel.
Wait for 10 minutes (i.e until the cleaning cycle is completed) before disconnecting the unit from the main supply by the yellow-red main switch.

The unit has got 2 solenoid valves (one for each cartridge filter) controlled by the pc board of the front panel. They are activated (alternating) every 10 secs.

A safety micro immediately stops the extraction in case the inspection door is opened: the alarm SAFETY SWITCH appears in the display.



FE320 HD



INFO



The cleaning system is programmed to restore a higher air flow rate than the minimum air flow rate necessary for efficient extraction.
During the cleaning cycle, the emission of airborne particles in the work area must be minimized.
Filter cleaning must not create a reverse flow causing particles to be released out of the extraction inlet point or from the body of the filter unit.
Airforce FE320 HD is equipped with a shutter system specifically designed to prevent a reverse air flow.

When the extraction is on the shutter system is open to allow the correct air flow direction through the cartridge filters.

The cleaning cycle automatically activates the shutter system to close the compartment involved by cleaning and avoid any reverse air flow.

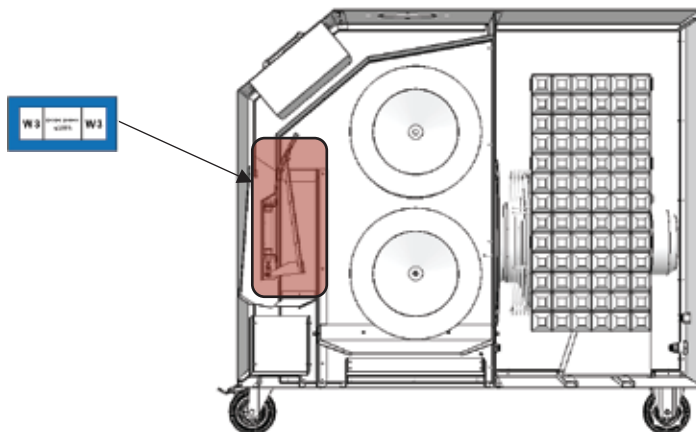

7. REGULAR MAINTENANCE

The instructions in this chapter correspond to the minimum requirements.

Depending on particular operating conditions, other specific instructions may be applicable to keep the unit in perfect conditions.

The maintenance and repairs described in this chapter may only be performed by qualified personnel.

The spare parts used must correspond to the technical requirements established by the Manufacturer.

This is always guaranteed if original spare parts are used.

Dispose in a safe and environmentally friendly way of the materials used and the components replaced.

Respect the following instructions during maintenance:

- Chapter 2.4 Safety warnings for the operator;
- Chapter 2.5 Safety warnings for maintenance and troubleshooting;
- Specific safety warnings, reported in this chapter in correspondence with each intervention.



FE320 HD

7.1. CARE

Taking care of the unit essentially means cleaning the surfaces, removing dust and deposits, and checking the condition of the filters.

Follow the warnings indicated in the "Safety instructions for repairing and troubleshooting" chapter.



WARNING

Skin contact with dust and other substances deposited on the unit can cause irritation to sensitive persons!
Danger of serious damage to the respiratory system!
To avoid contact and inhalation of dust, it is recommended to use protective clothing, gloves and a mask with a FFP2 class filter according to EN 149 standard.
During cleaning, prevent dangerous dust from being diffused in order to avoid damage to the health of persons nearby.



INFO

The unit must not be cleaned with compressed air!
Particles of dust and / or dirt could be diffused in the surrounding environment.

Adequate consideration helps to keep the unit in perfect order for a long time.

- The unit shall be cleaned thoroughly every month.
- The external surfaces of the unit shall be cleaned with a "H" class industrial vacuum cleaner suitable for dust, or with a damp cloth.
- Check that the suction arm is not damaged, and that there are no breaks / cracks in the flexible hose.

7.2. Ordinary maintenance

To ensure a safe operation of the unit, it is advisable to carry out a maintenance activity and overall check at least once every 3 months.

The unit does not require any specific maintenance, except for the replacement of the filters if necessary and the inspection of the articulated arm.

Follow the warnings given in paragraph 2.5 "Safety warnings for maintenance and troubleshooting".

7.3. Dust collector drawers

Any dust and powders falling down by gravity or by the automatic cleaning system are collected in the bottom drawers.

The capacity of the first drawer is 7,4 L and the capacity of the drawer under the cartridges is 4,5 L.

It is necessary to clean both drawers every month. It is up to the end user to realize if the frequency should be higher according to quantity of dust extracted.



FE320 HD



WARNING

It is forbidden to empty the drawers on baskets or other containers.
Broken drawers always need replacing!



WARNING

Skin contact with dust and other substances deposited on the unit can cause irritation to sensitive persons!
Danger of serious damage to the respiratory system!
To avoid contact and inhalation of dust, it is recommended to use protective clothing, gloves and a mask with a FFP2 class filter according to EN 149 standard.
During cleaning, prevent dangerous dust from being diffused in order to avoid damage to the health of persons nearby.
To this purpose, carefully insert the dirty filters inside bags with sealing and use an industrial vacuum cleaner for dust with efficiency class "H" to suck up any dust dropped during the filter extraction phase.

7.4. Safety filter and active carbons filter

The unit UNI 3 is provided with a particular safety filter behind the discharge grid. This filter has got two functions:

1. Safety
In case the filter media of the cartridge could be damaged, any dust leaks would be partially captured by this filter avoiding recycling in the work environment.
2. Flow-equalizer
The particular structure of this filter, made of PE + PP, allows a uniform discharge flow of the filtered air avoiding annoying turbulences in the surrounding area.

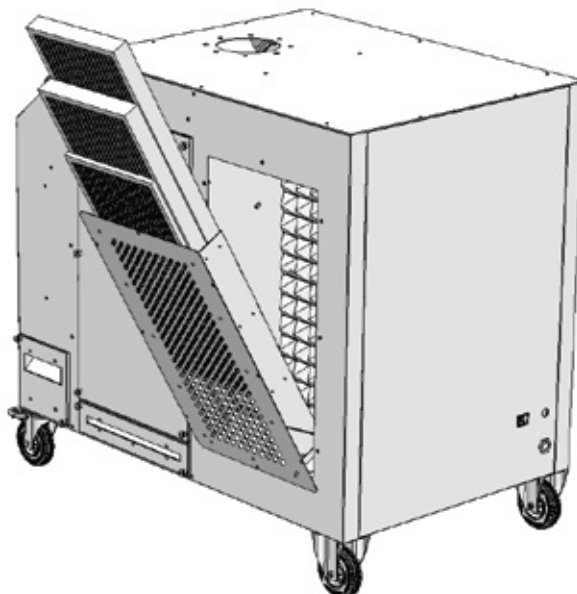



FE320 HD

The active carbons filters (2x 5 kg) can be mounted in the slots behind the discharge grid. They can absorb up to 20-30% of their original weight.

When each filters weighs 6,5 kg, it needs replacing.



INFO

Active carbons filters should be replaced at least every year.
Active carbons are absorbing SOV also when the unit is not working.
For that reason they can exhaust themselves independently from the hours of activity of the unit!

In the standard version the type of carbon supplied is mineral and comes in small cylinders enclosed within the filter structure. It is possible that for particular needs the carbon may be different, for example of vegetable type or chemically impregnated depending on the uses.

In case of specifications different from the standard, please refer to the machine's CE plate; Read paragraph 3.5 "Symbols and labels placed on the machine".

7.5.Replacement of filters

The lifetime of the filters depends on the kind and quantity of particles extracted.

To optimize the life of the main filter and to protect it from coarser particles, all units UNI 3 are provided with a decanting system for dust and powders. Refer par. 7.3 "Dust collector drawers".

The unit is provided with an automatic cleaning system by compressed air which ensures long life of the cartridge filters. Refer par. 5.3 "Electric and pneumatic connections".

The more are clogged the filters the narrower is the air flow, with an important reduction of the extraction capacity. The differential pressure switch triggers an alarm on the front panel advising the end user to replace the filters.

If active carbons filters are installed in the unit, they should be replaced at least once a year. Refer par. 7.4 "Safety filter and active carbons filter".

Airforce FE320

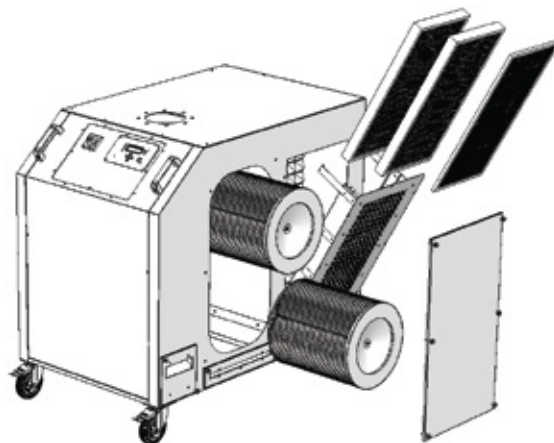



FE320 HD



INFO



The acoustic alarm is triggered whenever the air flow capacity goes under the minimum value.



WARNING

It is forbidden to clean fabric filters (all kinds): corrugated, pocket and cartridge filters. Cleaning would cause damage to the filter stuff, compromising the function of the filter and leading to escape of hazardous substances into the ambient air. In case of a cartridge filter, pay particular attention to the filter seal; only if the seal is free from damages or imperfections it is possible to guarantee a high level of filtration. Filters with damaged seals shall always be replaced.



WARNING

Skin contact with dust and other substances lying on the unit can cause irritation to sensitive persons!
Danger of serious damage to the respiratory system!
To avoid contact and inhalation of dust, it is recommended to use protective clothing, gloves and a mask with a FFP2 class filter according to EN 149 standard.
During cleaning, prevent dangerous dust from being diffused in order to avoid damage to the health of other persons.
To this purpose, carefully insert the dirty filters inside bags with sealing and use an industrial vacuum cleaner for dust with efficiency class "H" to suck up any dust dropped during the filter extraction phase.

Proceed with the following instructions:

- Use only original replacement filters, as only these filters can guarantee the required filtration level and are suitable for the unit and its performance.
- Turn off the unit by the yellow-red main switch.
- Secure the unit by pulling out the plug from the mains, so that it cannot be accidentally restarted.
- Disconnect the compressed air supply.
- Open the inspection door on the side of the unit.

a) Replacing the cartridge filter

- Carefully unscrew the lob knob.
- Insert a bag around the cartridge filter, taking care to avoid any lifting up of dust. Suitable plastic bags can be supplied by the Manufacturer.
- Take out the cartridge in the bag and close it firmly.
- Insert a new cartridge filter on the treaded rod and tighten again the lob knob.



FE320 HD

b) Replacing the safety filter

- Open the discharge grid.
- Carefully take out each filter avoiding any dust diffusion and place it in a sealed plastic bag.
- Insert the new filter in the slots and close the door.

c) If active carbons filters are provided, proceed as follows:

- Open the air grids on the side of the unit.
- Carefully take out each filter avoiding any dust diffusion and place it in a sealed plastic bag.
- Insert the new filters in the guides in the slots and close the door.

d) Once the filters have been replaced, proceed as per the following steps:

- Close the inspection door and check that it is completely closed and that the sealing gasket is positioned correctly.
- Reinsert the plug into the mains socket and turn on the yellow-red main switch.
- Reset alarms as indicated under point 7.4.
- Dispose of the dirty filters according to the regulations in force locally. Ask the local waste disposal company for the relevant waste disposal codes.
- Finally clean the surrounding area, e.g. with an "H" class industrial vacuum cleaner for dust.



FE320 HD

7.6. Digital control panel: alarms and alarm reset

The mobile air cleaner is equipped with a pc board for the control and setting of all functions.

Picture no. 1 shows the front panel where the user can set and read data.

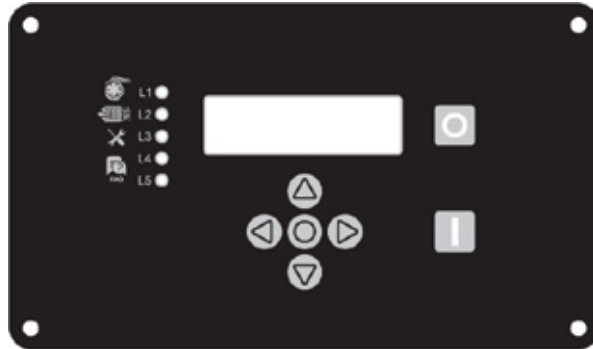

[picture 1: pc board layout]

Alarms are managed by the software in the following way:

- **(L2) FILTER EXHAUST:** it turns on when the filter pressure differential gauge detects a specific difference value (set by the Manufacturer) between the inlet of dirty air and the outlet of clean air on the filter.
- **(L3) MAINTENANCE:** it turns on after 600 hours of operation to indicate that an overall check of filters is necessary (if not cleaned or replaced before) and of the unit as well, to verify if it operates correctly.
- **(L4) FAQ:** it turns on when the compressed air is not connected or when the pressure is not above 4 bar. Steady red light.
- **(L5) FAQ:** it turns on when the electrical phases are not correctly connected (in case of three-phase units). Steady red light.

In addition to the visual alarm on the control panel, the unit is also equipped with an acoustic signal generated by a buzzer.

On the pc board there are the following menus:

- TEST MENU
- USER MENU
- ASSISTANCE MENU
- FACTORY MENU

When the Filter Exhaust alarm turns on, it is necessary to replace the filters as indicated under point 7.3 and to reset alarms in order to restore normal operation.

To carry out the reset it is necessary to enter the **USER** menu.

To enter the User menu just press once the button: central circle (O).



Then the unit will request a password, which is the following key sequence: central circle (O) + central circle (O) + central circle (O) + central circle (O) + central circle (O) + central circle (O).

Once you have entered the menu, scroll down (↓) to the third position ALARMS RESET.



FE320 HD

Press the central button (O) to go in and then type the following key sequence: arrow down (↓), arrow down (↓), arrow up (↑), arrow up (↑), circle (O), circle (O).

At this point the alarms are reset and all settings return to zero.

Remember that alarm reset is linked with the maintenance, cleaning or replacement of the filters.

The Manufacturer cannot be held liable for any breakdowns, malfunctions or shorter lifetime if alarms reset and maintenance are not carried out according to the present provisions.

The Manufacturer provides the unit with all alarm functions activated. Any deactivation of alarm is not attributable to the Manufacturer but to interventions carried out by the user or, eventually, by the dealer.

The Manufacturer recommends not to turn off any alarm, in order to maintain a high level of control over the unit and the maintenance of filters and to safeguard the performance of the unit and the health of the user.



WARNING

It is strictly forbidden to reset the alarms without having performed the necessary maintenance!

The Manufacturer is exonerated from any responsibility if these instructions are not respected.

The alarms on the display are controlled by a software, as follows:

- **A01 - PRESS. SENSOR:** analogic pressure switch not connected or tripped (the unit UNI 3 does not foresee this).
- **W01 - DIRTY FILTER:** alarm for dirty filter (as determined by the parameter DIRTY FILT. EDGE in the factory menu: 600 h); the led FILTER 80% is activated.
- **W02 - EXHAUST FILTER:** alarm for exhaust filter (triggered by the digital pressure switch); the led FILTER EXHAUST is activated.
- **W03 - LOW AIR PRESS:** alarm for low compressed air pressure (terminal block J11 - AUX IN 1 open if enabled by the parameter). The unit can work and the led light L4 turns on (steady red light).
- **W04 – PHASE SEQUENCE RELAY:** alarm for reverse rotation direction of the motor. The unit cannot work and the led light L5 turns on (steady red light).



7.7. Troubleshooting

FAILURE	POSSIBLE CAUSE	ACTION REQUIRED
The unit does not turn on	No power supply	Contact an electrician
	Pc board protection fuse is blown	Replace the 5x20 3.15A fuse
	The Start / Stop sensor (optional) is connected but does not detect any current	Ensure that the ground cable of the welding unit is correctly clamped on the filter units Start welding, if you have not yet
The extraction capacity is poor	Filters are dirty	Replace filters
	Wrong rotating direction of the motor (three-phase 400V version)	Consult an electrician to reverse two phases in the CEE plug
Presence of dust in the air discharge grid	Damaged filters	Replace filters
Not all fumes are captured	Excessive distance between the capture hood and the welding point	Bring the hood closer
	Manual damper is rather closed	Fully open the damper
The buzzer is activated, as well as the red led FILTER EXHAUST 	The extraction capacity is too low	Replace filters

Alarms related to the pcb

FAILURE	POSSIBLE CAUSE	ACTION REQUIRED
W-01 maintenance	Functioning is 600 h	Perform maintenance and alarm reset (par. 7.4)
W-02 exhaust filter	Dirty filters	Perform maintenance and alarm reset (par. 7.4)
W-03 low air pressure	Lack of compressed air	Connect the compressed air
W-04 phase sequence	Wrong connection (3-phase 400V)	Ask an electrician to switch 2 phases in the CEE plug
Safety switch	The filter inspection door is open	Check the door and the correct functioning of the micro switch



7.8. Emergency measures

In the event of a fire in the unit or in its suction device, proceed as follows:

- Disconnect the unit from the mains supply, removing the plug from the socket, if possible.
- Try to extinguish the outbreak of fire with a standard powder extinguisher.
- If necessary, contact the fire brigade.



WARNING

Do not open the inspection doors of the unit.
Possibility of flare-ups!
In case of fire, do not touch the unit for any reason without suitable protective gloves.
Danger of burns!

8. DISPOSAL



WARNING

Skin contact with dangerous fumes etc. can cause skin irritation in sensitive individuals.
The disassembly of the unit shall be carried out exclusively by specialized personnel, trained and authorized, in compliance with the safety instructions and the regulations for accident prevention.
Possibility of serious damage to health, affecting the respiratory system.
To avoid contact and inhalation of dust, wear protective clothing, gloves and a respirator!
Avoid any diffusion of dangerous dust during disassembly, in order not to jeopardize the health of people nearby.
Use a class "H" industrial vacuum cleaner to clean up the area.



WARNING

For all activities performed on and with the unit, comply with the legal obligations for the prevention of accidents and for correct recycling / disposal of waste.

8.1. Plastics

Any plastic materials shall be picked out as much as possible and disposed in compliance with legal obligations.

8.2. Metals

Metals, such as the cabinet of the unit, shall be separated and disposed in accordance with the local regulations. Disposal shall be carried out by an authorized company.

8.3. Filter media

Any filtering media used shall be disposed of in compliance with local obligations.



FE320 HD

9. ATTACHMENTS

9.1. Technical data Airforce FE320 HD / 1-2 arms / 2 cartridges

FILTRATION DATA

DESCRIPTION	UM	VALUE	NOTES
FILTERING STAGES	No	3	Spark arrestor - cartridge filter – safety filter
FILTERING SURFACE	m ²	12,6	Cartridge filter
FILTER	Material	FE2577 – sinTexx Plus	Cartridge filter
EFFICIENCY		≥ 99%	Cartridge filter
DUST CLASSIFICATION	DIN EN 60335-2-69:2010	M	Test report num.: 201520666/6210 Cartridge filter
FILTERING MEDIA WEIGHT	g/m ²	230	Cartridge filter
ACTIVE CARBONS	Kg	10 (5+5)	Optional

EXTRACTION DATA

DESCRIPTION	UM	VALUE	NOTES
<i>Version with 1 arm</i>			
EXTRACTION CAPACITY	m ³ /h	1.400	Measured with clean filters Unit with 1 arm
MAX FAN CAPACITY	m ³ /h	2.520	
NOISE LEVEL	dB(A)	75	
<i>Version with 2 arms</i>			
EXTRACTION CAPACITY	m ³ /h	2.000 (2x1.000)	Measured with clean filters Unit with 2 arms
MAX FAN CAPACITY	m ³ /h	2.520	
NOISE LEVEL	dB(A)	75	
<i>Single-phase version</i>			
MOTOR POWER	kW	1,5	
MAINS SUPPLY	V/ph/Hz	230/1/50	
ABSORBED CURRENT	A	9,50	

ADDITIONAL INFORMATION

DESCRIPTION	UM	VALUE	NOTES
EXTRACTOR	Type	Plug fan	
CLOGGED FILTER ALARM	Pa	1200	Differential pressure switch
START&STOP	Type	automatic	Optional
DIMENSION	mm	740x1180x1100	
WEIGHT	Kg	182	
AIR CONSUMPTION	l/min	150	
AIR PRESSURE	bar	6	

9.2. Spare parts and accessories

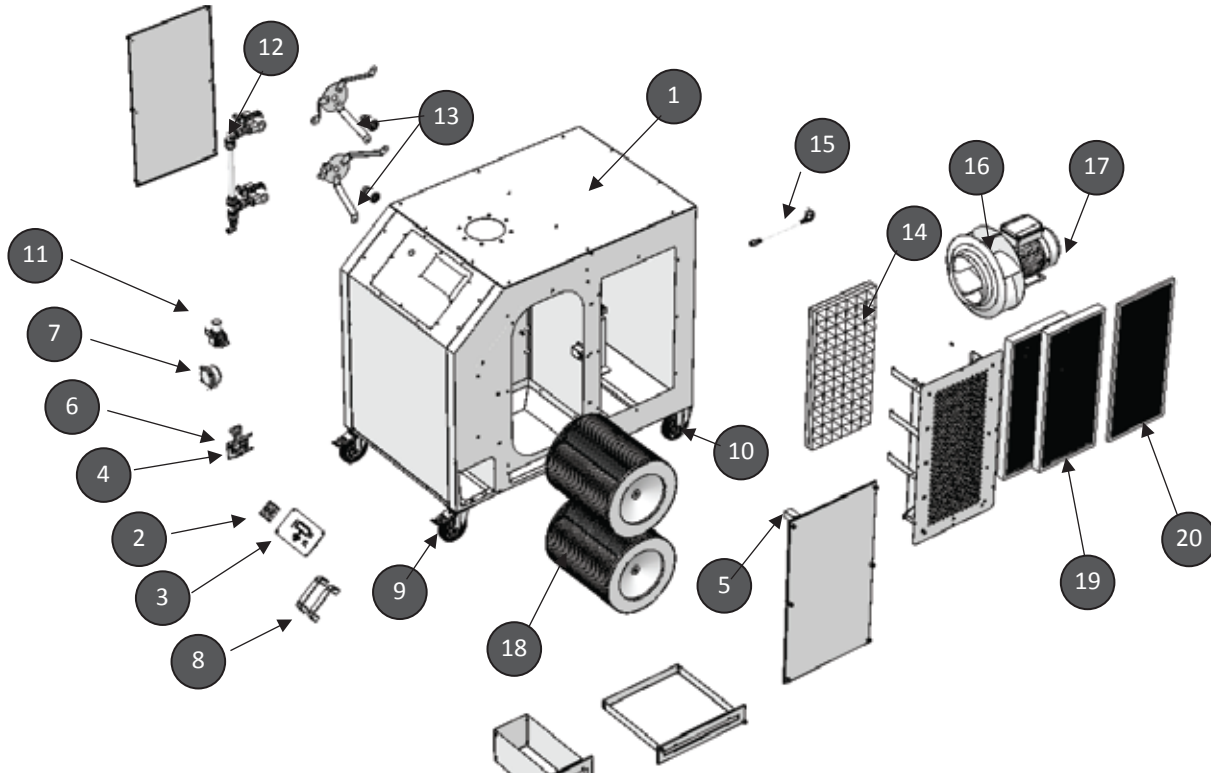

N°	P/N	UM	Q.ty	Description
1	50UNI30009005	No	1	Unit cabinet
2	2050060	No	1	16A main switch
3	DBCENTOM230000	No	1	Control pc board
4	DBCENTOM2300SS	No	1	Start/stop pc board
5	2300075	No	1	Safety micro for filter inspection door
6	DB90000	No	1	Clamp for the ground cable of the welding unit
7	3240005	No	1	Differential pressure switch
8	DBMANUNI20	No	2	Handle
9	DBRUOTAFRENO	No	2	Swivel castor with brake
10	DBRUOTAFISSA	No	2	Rear castor
11	COM00167	No	1	Air pressure regulator
12	3240076	No	1	Solenoid valve 230Vac
13	JOMUG001POM120	No	1	Multi-nozzle device
14	DBG0023	No	1	Soundproof layer
15	DBPZ3061530LK0	No	1	Electric cable C19
16	DBGIRANTE350	No	1	Impeller
17	DBM90152PMB3	No	1	Extractor fan 1phase 230V 1.1kW
	DBM90152PTB3	No	1	Extractor fan 3phase F 400V 1.1kW
18	RFOUNI3200001	No	1	Set of replacement filters : 2 cartridges + 1 safety filter
19	RFOUNI3200002	No	1	Set active carbon filter [5+5Kg]
20	RFOUNI3200003	No	1	Safety filter



FE320 HD

9.3. Dimensional drawing

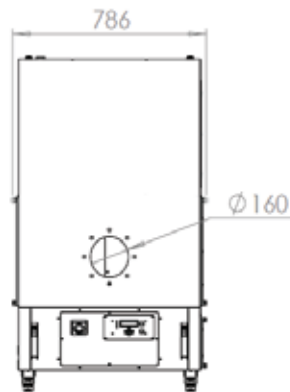
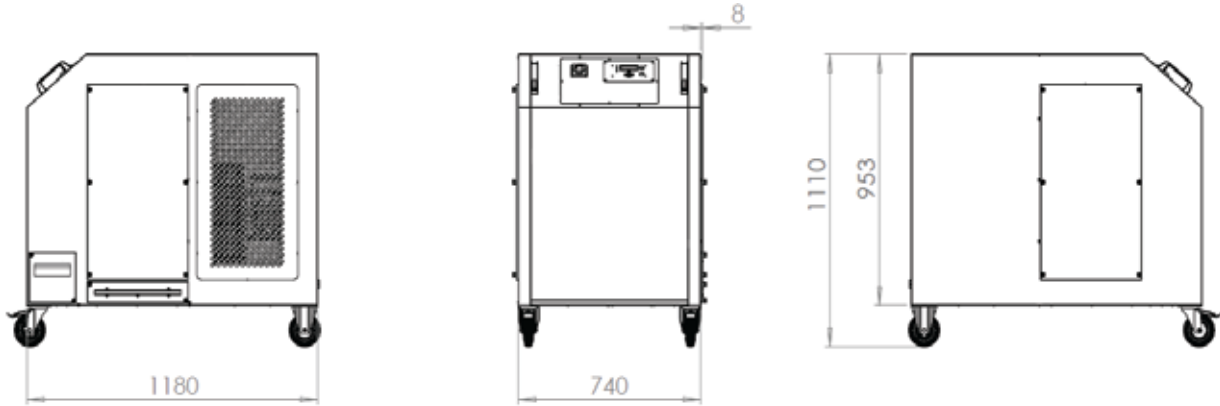

9.4. Wiring diagram Airforce FE320 HD 230V

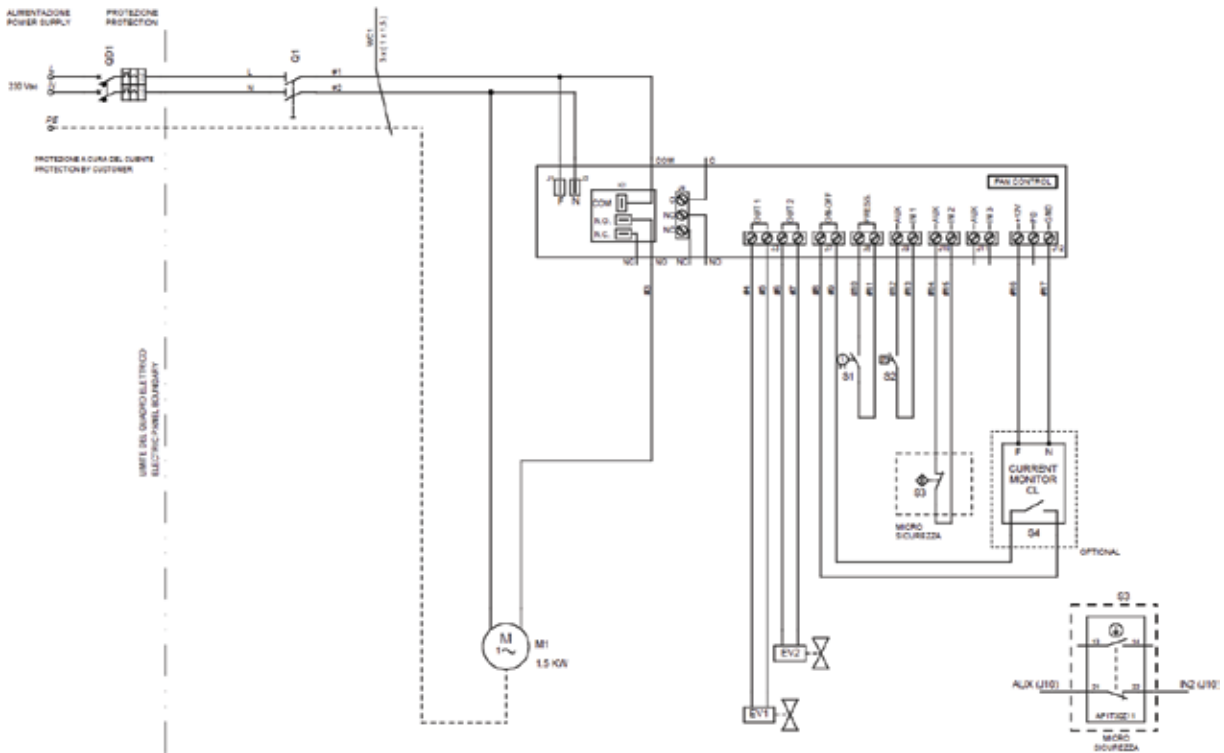

9.5. Wiring diagram Airforce FE320 HD 400V

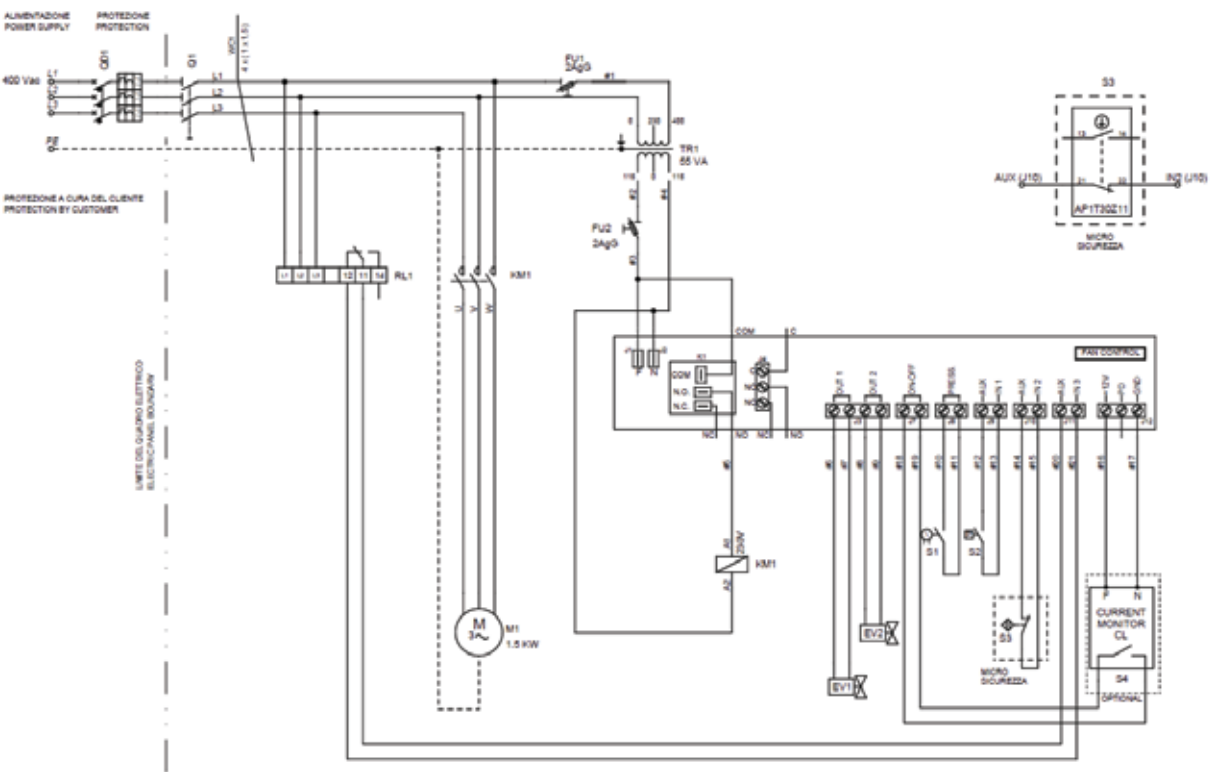

9.6. Pneumatic diagram FE320 HD

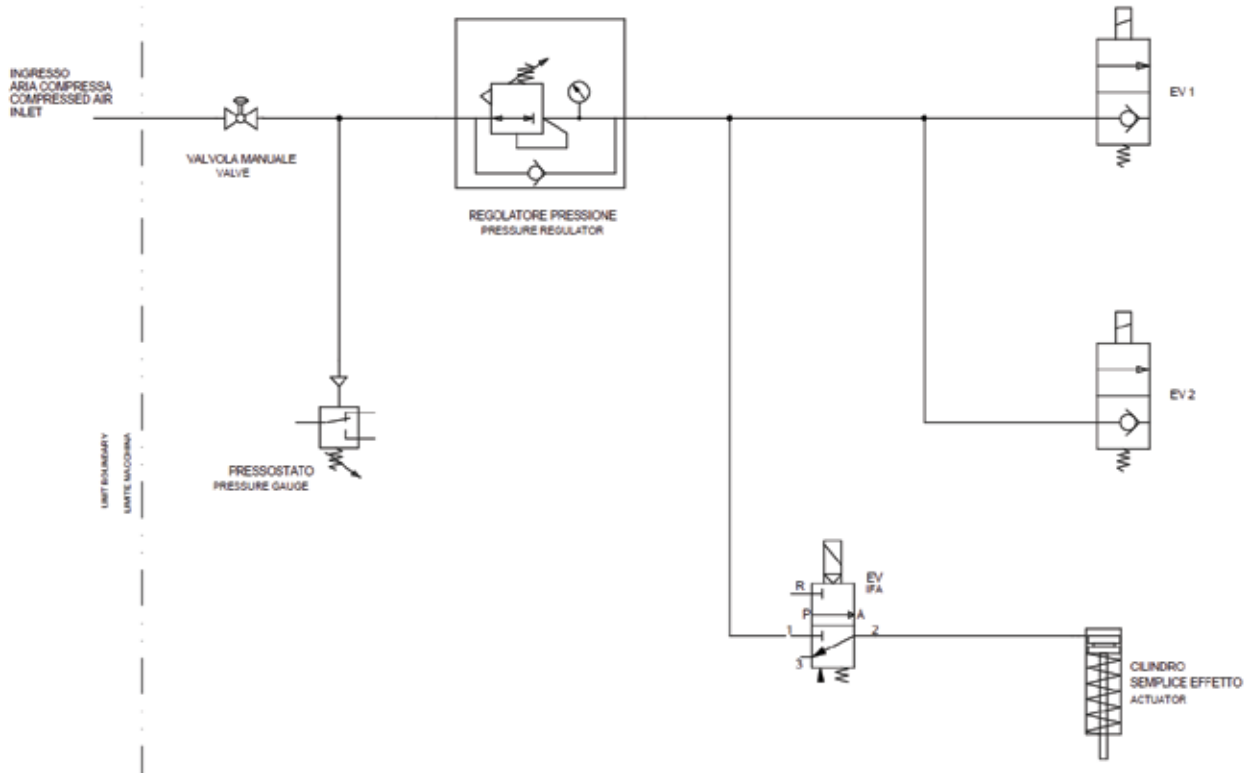



FE320 HD

Warranty

As part of an on-going commitment to excellence in product support, Euroquip offers a comprehensive product warranty program.

Warranty period for the Strata Airforce FE320 HD:

Commercial Use: 24 Months

Domestic Use: 24 Months

Warranty covers failure caused by manufacturing and material defects in the product, during the warranty period specified. The warranty period begins when the product is purchased by the end user. Warranty is not transferrable and is only claimable by the original purchaser.

Warranty does not cover parts that are subject to wear and tear from usage, such as hoses, filters etc.

Warranty covers failure of a product caused by defective materials and/or manufacturing for the period given and the usage specified by Euroquip. The warranty period begins when the product is purchased by the end user. Warranty is not transferrable and is only claimable by the original purchaser.

Warranty also does not cover failure caused by the untimely replacement or service of the above wearing parts. Evidence must be provided that the product has been maintained and serviced suitably for a claim to be considered under warranty.

Failure caused by incorrect operation of the product, lack of proper care and maintenance of the product, external damage, external circumstances such as poor power, non standard filter usage, modifications to the product, attempted repair/ service by a party other than an Approved Service Agent, is not covered under warranty.

Warranty does not cover pre delivery service and adjustment, or failure that may occur as a result of lack of/ incorrect pre delivery service and adjustment.

Warranty does not cover any incidental, indirect or consequential loss, damage or expense that may result from any defect, failure or malfunction of a product.

Should any issue be found to be a combination of a warranty failure and a non-warranty issue, the repair cost component to rectify and repair the non-warranty failure is the customers' full responsibility.

The decision that an issue with a product qualifies as a warranty claim is made at the sole jurisdiction of Euroquip.

No costs incurred will be considered under warranty if repairs are carried out by a party other than a Euroquip Approved Service Agent, unless with prior consent in writing from Euroquip.

It is the responsibility of the purchaser to deliver a product under warranty to the nearest relevant service agent or product reseller. Warranty does not cover call outs, mileage and freight costs.

If a product is repaired under warranty, parts and labour required for the repair will be supplied at no charge. Warranty assessment and repair will be scheduled and executed according to the normal work flow at the service location and depending on the availability of suitable replacement parts.

This warranty policy is an additional benefit and does not affect the legal rights of any end user, reseller or service agent.



FE320 HD



FE320 HD



FE320 HD



Congratulations on your new STRATA product. We are proud to have you as our customer and will strive to provide you with the best service and reliability in the industry. This product is backed by our extensive warranty and world-wide service network. To locate your nearest distributor or service agency visit www.strata.co.nz, or email us at customerservice@euroquip.co.nz

www.strata.co.nz